

# 水平式快速夾鉗

Horizontal quick clamp



DK-225



[DK-225-1-1] 不鏽鋼  
[DK-225-1-2] 高碳鋼



[DK-225-2] 高碳鋼

[DK-225-1-1] 不鏽鋼  
[DK-225-1-2] 高碳鋼

## 商品介紹 Product description

1. 壓把開啟角度：90度。
2. 手柄開啟角度：65度。
3. 最大夾持力：227公斤。

- 材質：高碳鋼、不鏽鋼
- 備註：DK-225-1=空心壓背、法蘭底座  
DK-225-2=空心壓背、直底座

1. Opening angle of the handle : 90 degrees.
2. handle opening angle : 80 degrees.
3. Maximum clamping force: 227 kg.

- Material: High carbon steel, stainless steel
- Notes: DK-225-1=Hollow pressure back, flange base  
DK-225-2=Hollow back, straight base

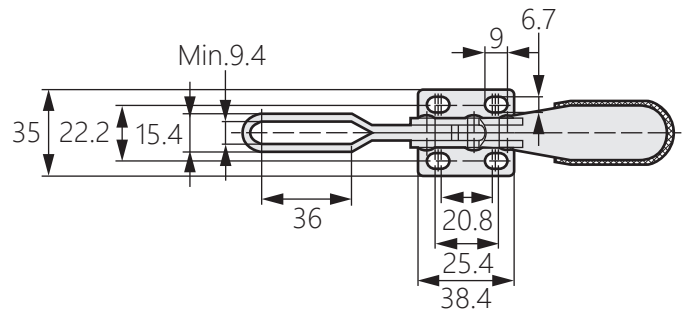
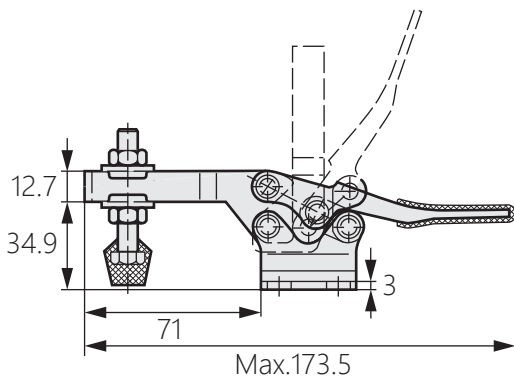

[DK-225-2] 高碳鋼

