

AC型交叉滾柱導軌

AC type crossed roller guide

HG-AC9

商品介紹 Product description

1. 安裝簡易方便。
2. 內有防蠕動齒輪，可防止保持架錯位。
3. 快速平穩的滾動運動。
4. AC9型交叉滾柱保持架的最大長度是700mm。

● 材質：導軌-軸承鋼、保持架-聚甲醛、鉻軸承鋼

1. Easy and convenient installation.
2. Equipped with anti-creep gears inside to prevent misalignment of the cage.
3. Fast and smooth rolling motion.
4. The maximum length of AC9 type crossed roller cage is 700mm.

● Material: Guide rail-bearing steel
Cage-POM、GCR15

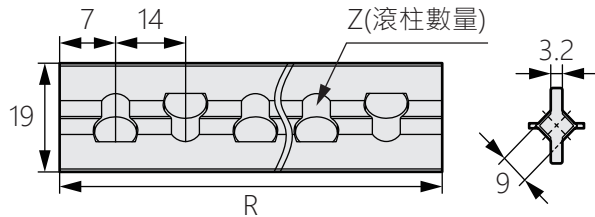
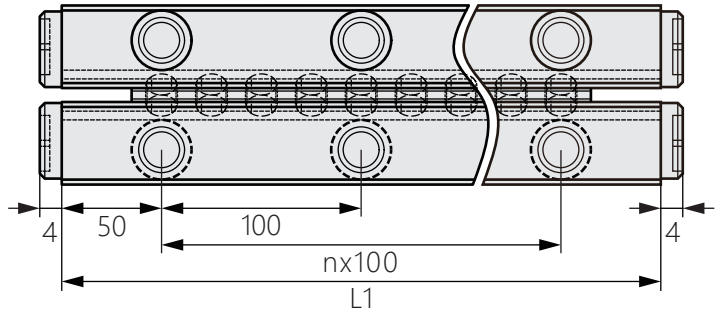
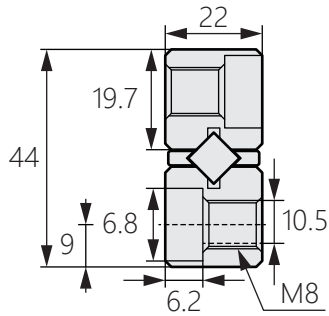

商品型號	L1	nx100	R	最大行程(mm)
HG-AC9-200X10Z	200	1x100	140	120
HG-AC9-300X15Z	300	2x100	210	180
HG-AC9-400X20Z	400	3x100	280	240
HG-AC9-500X25Z	500	4x100	350	300
HG-AC9-600X30Z	600	5x100	420	360
HG-AC9-700X35Z	700	6x100	490	420
HG-AC9-800X40Z	800	7x100	560	480