

鍍黃鋅通花PA輪



JZ-430

Yellow zinc plated through flower PA wheel

商品介紹 Product description

1. 一體拉伸成型支架。
2. 雙層滾珠設計。

- 材質：鋁芯雙軸PA輪
- 用途：重工業、重負荷物流台車、重型機械設備、廚房設備及食品業

1. One-piece stretch forming bracket.
2. Double ball design.

- Material: Aluminum core double axle PA wheel
- Uses: Heavy-duty industrial logistics carts, machinery, kitchen equipment, food industry.



〔JZ-430-S〕活動式



〔JZ-430-R〕固定式



〔JZ-430-I〕煞車式

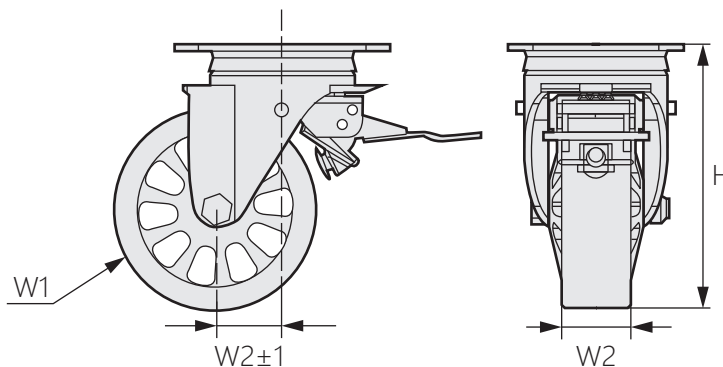
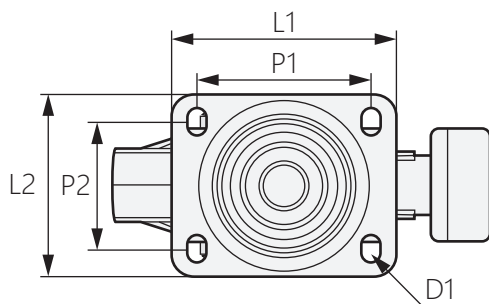

商品型號	輪子	輪徑(W1)	輪寬(W2)	安裝高度(H)	底板尺寸(L1*L2)	孔距(P1*P2)	孔徑(D1)	荷重 (KG)
JZ-430-1_	PA	100	45	140	135*110	105*77.5	10.5	320
JZ-430-2_		125		165				350
JZ-430-3_		150		191				380
JZ-430-4_		200		240				450

_可選配R固定/S活動/I煞車