



[JZ-506-1S]

- 1.一體拉伸成型支架。
- 2.加大雙層滾珠設計。
- 3.全覆式防塵蓋。

- 材質：雙軸承塑芯PU輪
- 用途：重工業、重負荷物流台車、重型機械設備、廚房設備及食品業

1. One-piece stretch forming bracket.
2. Enlarge the double-layer ball design.
3. Full-coverage dust cover.

- Material: Double bearing plastic core PU wheel
- Uses: Heavy industry, logistics carts, heavy machinery, kitchen & food equipment.



[JZ-506-1R]



[JZ-506-1K]



[JZ-506-1D]



[JZ-506-2S]



[JZ-506-2K]



[JZ-506-2D]



[JZ-506-3S]



[JZ-506-3K]



[JZ-506-3D]

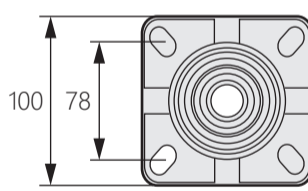
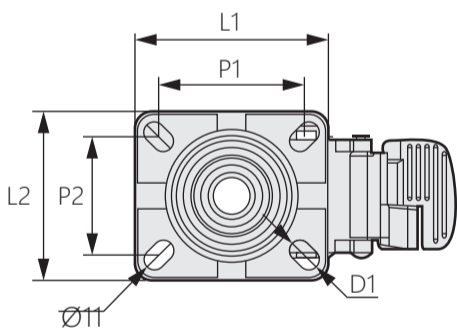

[日式底板]

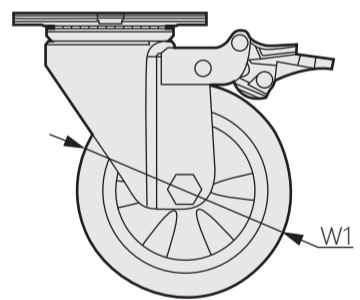

商品型號	輪子	輪徑 (W1)	輪寬 (W2)	安裝高度 (H)	底板尺寸 (L1*L2)	孔距 (P1-P2)	孔徑 (D2)	荷重 (KG)
JZ-506-1-1_	PU	100	38	138	110*85	83*60	11	200
JZ-506-1-2_		125		165	112*98	85*70		250
JZ-506-1-3_		150		193	112*98	85*70		280

JZ-506-1系列可選配R固定/S活動/K疊煞/D邊煞

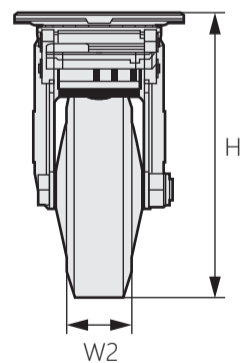

商品型號	輪子	輪徑 (W1)	輪寬 (W2)	安裝高度 (H)	底板尺寸 (L1*L2)	孔距 (P1-P2)	牙桿尺寸 (H2)	荷重 (KG)
JZ-506-2-1_	PU	100	38	138	110*85	83*60	M20*40	200
JZ-506-2-2_		125		165	112*98	85*70		220
JZ-506-2-3_		150		193	112*98	85*70		280

JZ-506-2系列可選配S活動/K疊煞/D邊煞

商品型號	輪子	輪徑 (W1)	輪寬 (W2)	安裝高度 (H)	底板尺寸 (L1*L2)	孔距 (P1-P2)	孔頂尺寸 (D2)	荷重 (KG)
JZ-506-3-1_	PU	100	38	138	110*85	83*60	Ø16	200
JZ-506-3-2_		125		165	112*98	85*70		250
JZ-506-3-3_		150		193	112*98	85*70		280

JZ-506-3系列可選配S活動/K疊煞/D邊煞