

PA尼龍輪

PA nylon wheel



JZ-602



[JZ-602-1S] 雙輪



[JZ-602-1R] 雙輪



[JZ-602-2S] 單輪

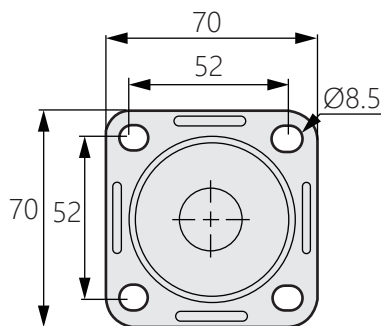

底板尺寸

商品介紹 Product description

- 1.一體拉伸成型支架。
- 2.一體成型雙軸單輪。
- 3.雙層滾珠設計。
- 4.加大雙波盤。

- 材質：PA輪(特殊配方工程尼龍輪)
- 用途：重工業、重負荷物流台車、重型機械設備、廚房設備及食品業

1. One-piece stretch forming bracket.
2. One-piece dual-shaft single wheel.
3. Double-layer ball design.
4. Increase the double-wave disc.

- Material: PA wheel
(Special formula engineered nylon wheel)
- Uses: Heavy industry, heavy-duty logistics carts, heavy machinery, kitchen & food equipment.

商品型號	輪子	輪徑 (W1)	輪寬 (W2)	安裝高度 (H)	底板尺寸 (L1*L2)	孔距 (P1-P2)	孔徑 (D2)	荷重 (KG)
JZ-602-1-1_	PA	38	45	68	70*70	52*52	8.5	100
JZ-602-1-2_		50		79				120
JZ-602-2S		50		200				

JZ-602-1系列可選配R固定/S活動