

商品介紹 Product description

1. 利用表面貼裝技術焊接到印刷電路板材料上。
2. 把手符合UL-1950標準。
3. 手動彈簧設計。
4. 具多種尺寸與頭型。

1. Solder to the printed circuit board material using surface mount technology.
2. The handle conforms to UL-1950 standard.
3. Manual spring design.
4. A variety of sizes and head shapes are available.

- 材質：導套-鋼、把手-鋁、螺釘-硬化碳鋼  
內部彈簧-300系列不鏽鋼鈍化、插塞:硅橡膠
- 表面處理：導套-鍍錫、把手-本色  
螺釘-鍍鋅/鉻酸鹽/加保護層、內部彈簧-鈍化

- Material: Guide bush-steel, handle-aluminum, screw-hardened carbon steel, inner spring-300 series stainless steel passivated, plug: silicone rubber
- Finish: Guide bush-tin plated, handle-natural color, screw-zinc plated/chromate/protective layer, inner spring - passivated



螺釘上表面用於真空拾取的聚酰亞胺膠帶貼布

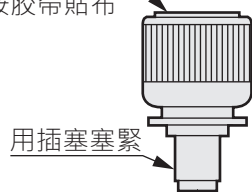

用插塞塞緊

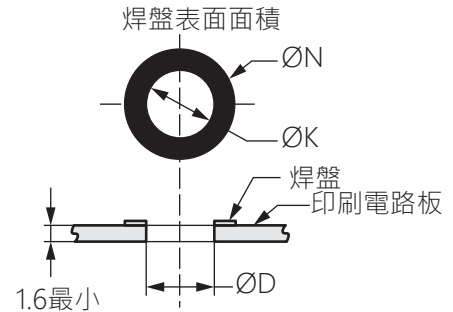
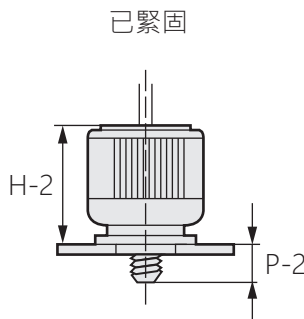
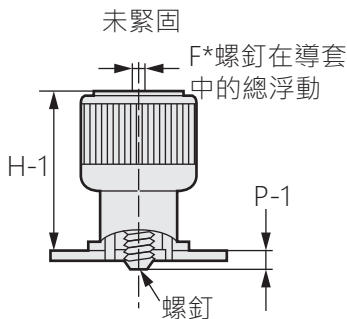
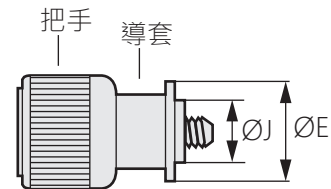
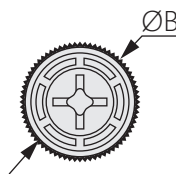

商品型號		螺紋	H-1	H-2	P-1	P-2	ØB	ØJ	ØE	F*	ØK	ØN	ØD
十字頭 / 一字頭	TORX® / 一字頭												
LZ-94-SM-3311-K-R	LZ-94-SM-3411-K-R	M3*0.5	11.4	8.4	1.4	4.4	10.7	5.5	7.6	0.7	5.6	8.6	5.6+0.08/-0
LZ-94-SM-3321-K-R	LZ-94-SM-3421-K-R				2.2	5.2							
LZ-94-SM-1311-K-R	LZ-94-SM-1411-K-R				1.4	4.4							
LZ-94-SM-1321-K-R	LZ-94-SM-1421-K-R	4-40	11.4	8.4	2.2	5.2	10.7	5.5	7.6	0.7	5.6	8.6	5.6+0.08/-0
LZ-94-SM-2311-K-R	LZ-94-SM-2411-K-R	0.8			5.6								
LZ-94-SM-2321-K-R	LZ-94-SM-2421-K-R	6-32	15.5	10.7	0.8	5.6	11.4	6.2	8.1	0.7	6.4	10.2	6.4+0.08/-0
					2.3	7.1							

商品型號		螺紋	H-1	H-2	P-1	P-2	ØB	ØJ	ØE	F*	ØK	ØN	ØD
十字頭 / 一字頭	TORX® / 一字頭												
LZ-94-SM-3311-N-R	LZ-94-SM-3411-N-R	M3*0.5	11.4	8.4	1.4	4.4	10.7	5.5	7.6	0.7	5.6	8.6	5.6+0.08/-0
LZ-94-SM-3321-N-R	LZ-94-SM-3421-N-R				2.2	5.2							
LZ-94-SM-1311-N-R	LZ-94-SM-1411-N-R				1.4	4.4							
LZ-94-SM-1321-N-R	LZ-94-SM-1421-N-R	4-40	11.4	8.4	2.2	5.2	10.7	5.5	7.6	0.7	5.6	8.6	5.6+0.08/-0
LZ-94-SM-2311-N-R	LZ-94-SM-2411-N-R	0.8			5.6								
LZ-94-SM-2321-N-R	LZ-94-SM-2421-N-R	6-32	15.5	10.7	0.8	5.6	11.4	6.2	8.1	0.7	6.4	10.2	6.4+0.08/-0
					2.3	7.1							