

冷凍庫鉸鍊



OH-0210

Refrigerator hinge



[OH-0210]



[OH-0210-S]

[OH-0210]

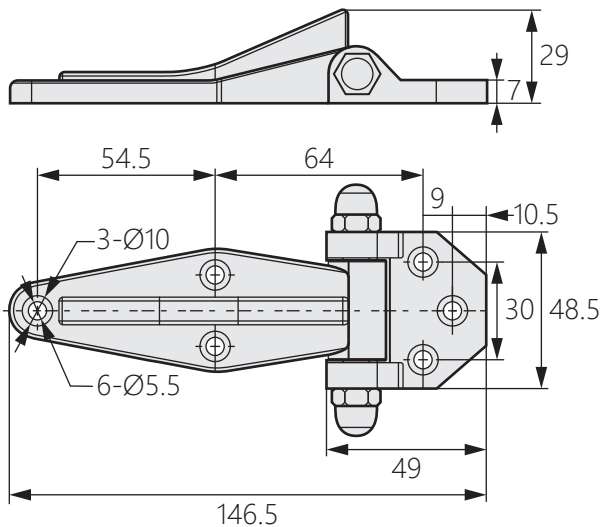

商品介紹 Product description

- 1.軸可以拆卸安裝。
- 2.六孔安裝，增加安裝的牢固性。
- 3.魚鱗式限位設計，最大開啟角度90度。

- 材質：OH-0210：鋅合金(ZDC)、OH-0210-S：不鏽鋼
- 表面處理：鍍亮鉻
- 用途：機箱機櫃、電器櫃等
- 備註：安裝時，使用M5沉頭螺絲

1. The shaft can be disassembled and installed.
2. Six-hole installation increases the firmness of installation.
3. Fin type limit design, the maximum opening angle is 90 degrees.

- Material: OH-0210: Zinc alloy (ZDC)
OH-0210-S: Stainless steel
- Finish: Bright chrome plating
- Uses: Chassis cabinets, electrical cabinets, etc.
- Notes: When installing, use M5 countersunk screws.

[OH-0210-S]

