

不鏽鋼小型鉸鏈



OH-2111

Stainless steel small hinge

商品介紹 Product description

- 1.旋轉角度：0-180度。
- 2.最大靜載荷：80KG。



- 材質：不鏽鋼(SUS304.316)
- 表面處理：鏡光、拉絲
- 用途：交通車輛、工業設備等

1. Rotation angle: 0-180 degrees.
2. Maximum static load: 80KG.

- Material: Stainless steel(SUS304.316)
- Finish: Mirror light,wire drawing
- Uses: Transportation vehicles,industrial equipment,etc.

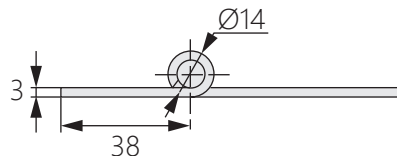
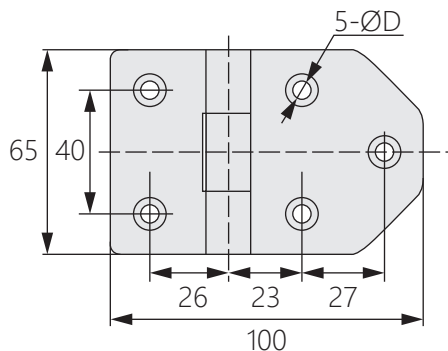

商品型號	D	孔類型
OH-2111-1	6.5	直孔
OH-2111-2	6.5	沉頭孔
OH-2111-3	8.5	直孔