

鋁合金短型鉸鍊



OH-847

Aluminum alloy short hinge

商品介紹 Product description

容許荷重視使用2pcs時的數值。

- 材質：鋁合金
- 表面處理：陽極處理
- 用途：機台、機櫃等

Allow charge value when using 2pcs.

- Material: Aluminum alloy
- Finish: Anodized
- Uses: Machines,cabinets,etc.

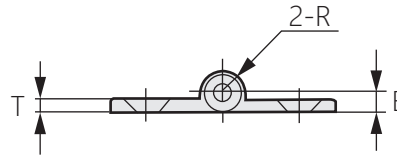
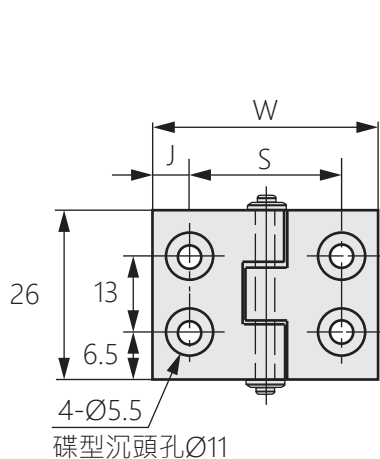

商品型號		W	J	S	T	E	R	荷重	
黑色	白色							KG	N
OH-847-1B	OH-847-1W	36	7.5	21	3.5	5	5	10	98
OH-847-2B	OH-847-2W	48	8	32		5.5	5.5		
OH-847-3B	OH-847-3W	62	10	42	4.5				15
OH-847-4B	OH-847-4W	80	16.5	47					