

嵌入式彈簧折疊把手



TG-504-3A

Embedded carrying handle (Spring load)

商品介紹 Product description

簡單的面板預製和螺絲安裝，彈簧式設計可快速抓取手柄。

- 材質：面盤-鐵、手柄-PVC
- 表面處理：黑色塗裝
- 用途：機箱機櫃、配分電盤等

Simple panel prefab and screw installation, spring-loaded design for quick grab handle.

- Material: Face plate-iron, handle-PVC
- Finish: Black coating
- Uses: Chassis cabinets, distribution panels, etc.

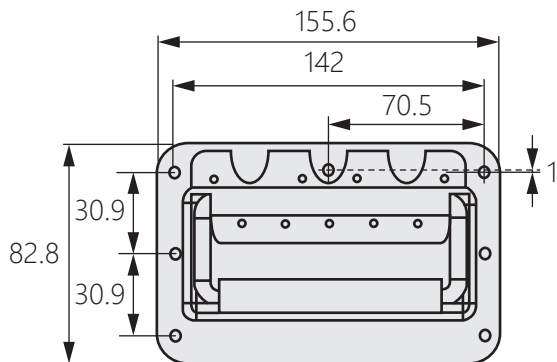

開孔尺寸

