

Automation equipment lock

商品介紹 Product description

1. 具有伸縮迫緊功能。
2. 調整鎖片可適合不同門板厚度。
3. 鎖片可正反裝配，以適應不同的板厚。



- 材質：鋅合金、冷軋板
- 表面處理：鍍亮鉻、黑亞光
- 用途：控制箱、電力箱、機箱機櫃

1. With telescopic compression function.
2. Adjust the lock plate to suit different door thickness.
3. The lock plate can be assembled front and back to adapt to different plate thicknesses.

- Material: Zinc alloy(ZDC) 、Cold rolled sheet
- Finish: Bright chrome plated 、Black matt.
- Uses: Control box, power box, chassis cabinet.

[TM-053-1]

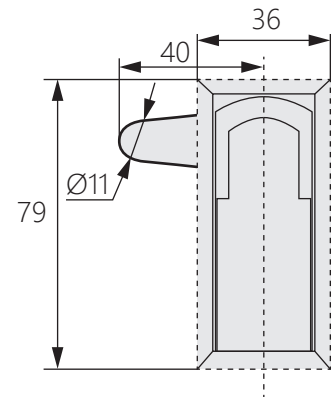
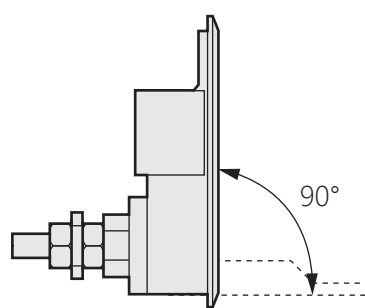
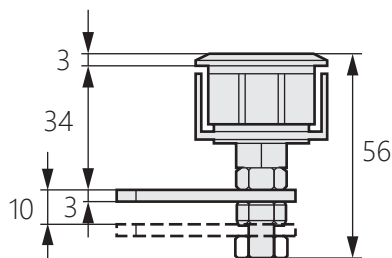

開孔尺寸

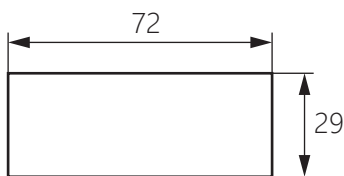

[TM-053-2]

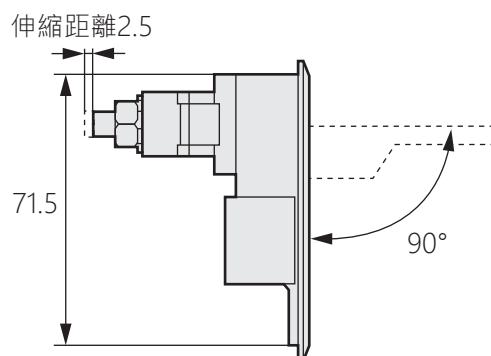
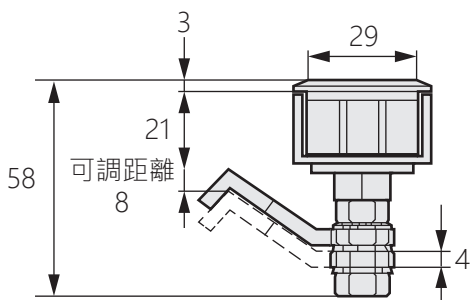

開孔尺寸

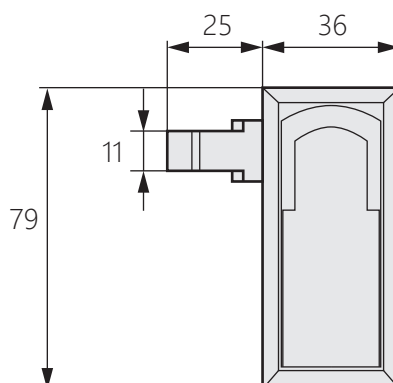
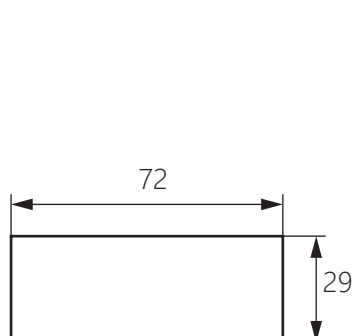

商品型號	表面顏色
TM-053-1	鍍亮鉻
TM-053-2	黑亞光