

防水雙鎖手柄



TM-1520

Waterproof double lock handle

商品介紹 Product description

1. 鎖柄可移動·附著力強。
2. 雙重鎖定具有出色的安全性。
3. 左右皆可使用·且左右旋轉角度：60度。
4. 有防水功能。



- 材質：鋅合金(ZDC)
- 表面處理：鍍鉻
- 用途：工業面板、測試儀器等

1. The lock handle can be moved and has strong adhesion.
2. Double locking for excellent security.
3. It can be used on both left and right sides, and the left and right rotation angle is 60 degrees.
4. It has waterproof function.

- Material: Zinc alloy(ZDC)
- Finish: Chrome plating
- Uses: Industrial panels, test instruments, etc.

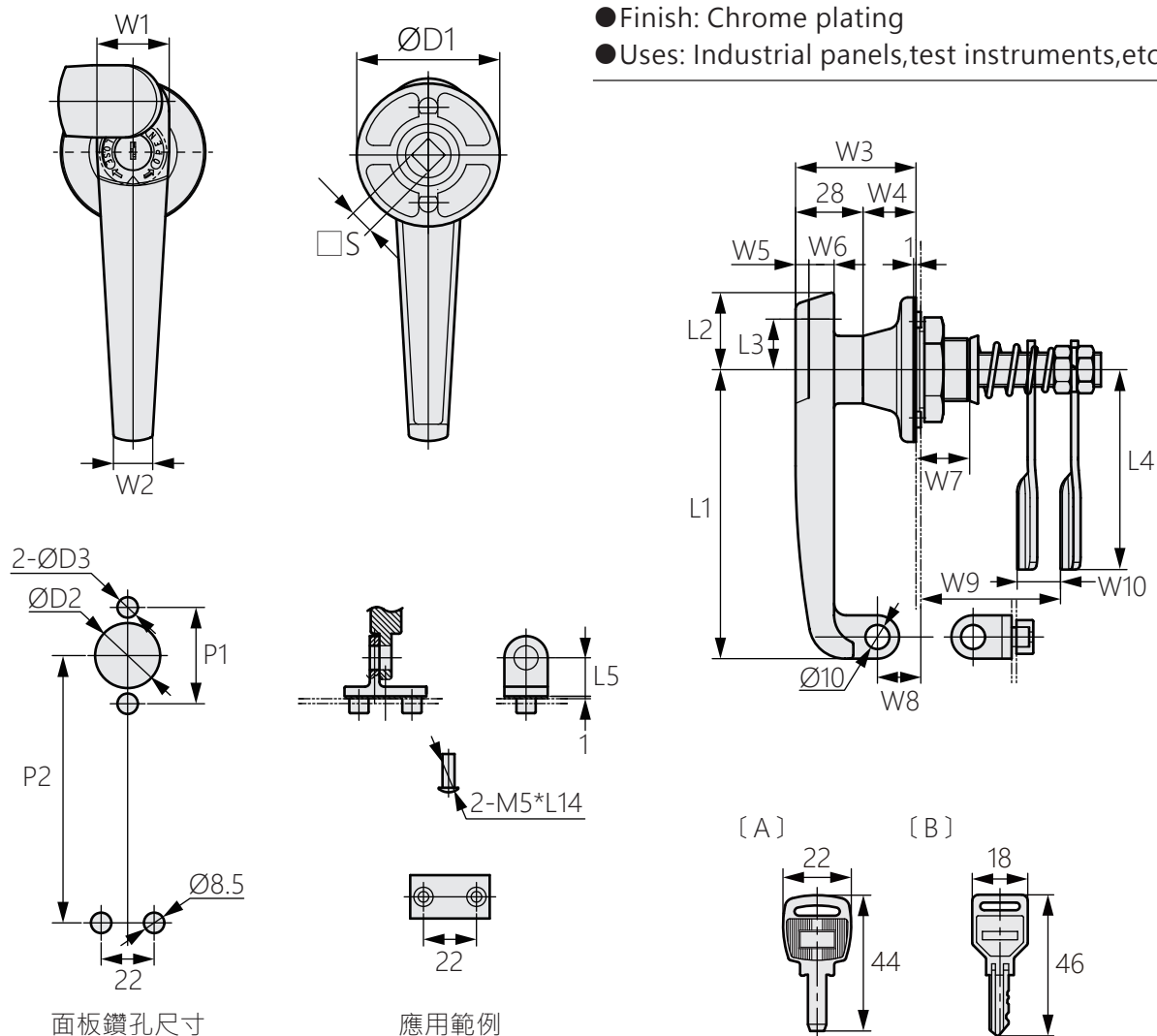

面板鑽孔尺寸

應用範例

*鑰匙有A/B兩款·可以選擇想要的款式·例如：TM-1520-1-A

商品型號	L1	L2	L3	L4	W1	W2	W3	W4	W5	W6	W7	W8	W9	W10	P1	P2	D1	D2	D3
TM-1520-1	120	32	21	83	30	16	50	22	5.5	10.5	22.3	16	62.5	18	40	111	60	27	8.5
TM-1520-2	95	25	16.5	60	24	13.5	43	15	5	10	15	13	46	10	32	85.7	48	23	7.5
TM-1520-3	79															67.8			