

Vibration device lock



商品介紹 Product description

1. 平面 T 型手柄，帶鎖芯鎖定。
2. 三點鎖閉結構，鎖芯帶防塵蓋。

- 材質：冷軋鋼板(SPCC)
- 表面處理：黑色烤漆
- 用途：特種車、改裝車、震動設備等
- 備註：為確保產品經久耐用，請定期在轉動部位上塗抹潤滑油。

1. Flat T-shaped handle with lock core lock.
2. Three-point locking structure, the lock core with a dust cover.

- Material: Cold rolled steel plate(SPCC)
- Finish: Black painting
- Uses: Special vehicles, modified vehicles, vibration equipment, etc.
- Notes: To ensure the product is durable, please apply lubricating oil on the rotating parts regularly.

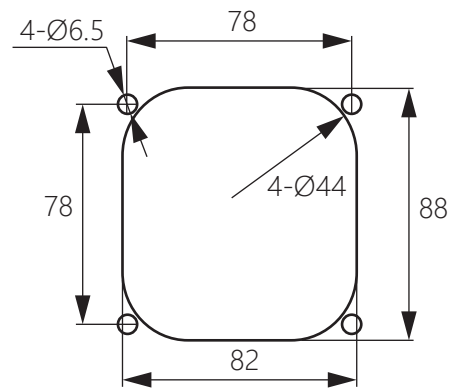
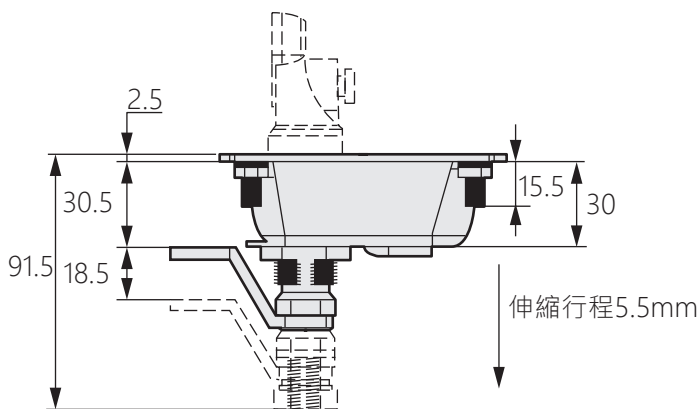
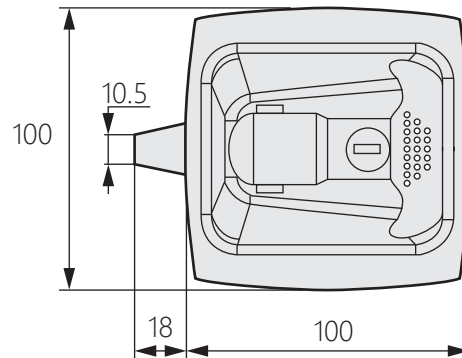
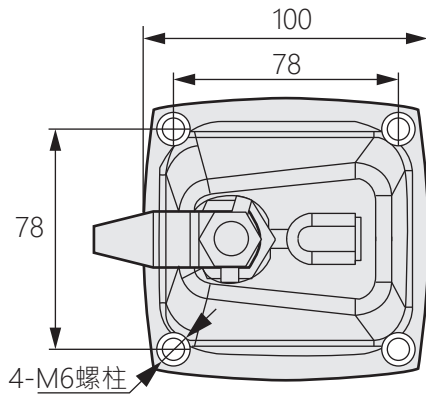

開孔尺寸