

通用手把



TM-517

General Handle



商品介紹 Product description

- 1.鎖柄可移動·附著力強。
- 2.左右分開·且左右旋轉角度：90度

- 材質：鋅合金(ZDC)
- 表面處理：鍍鉻、鍍黑鉻、衛星鍍鉻、鍍絨鉻
- 用途：測試儀器、控制面板等

1. The lock handle can be moved and has strong adhesion.
2. Separate left and right, and left and right rotation angle: 90 degrees.

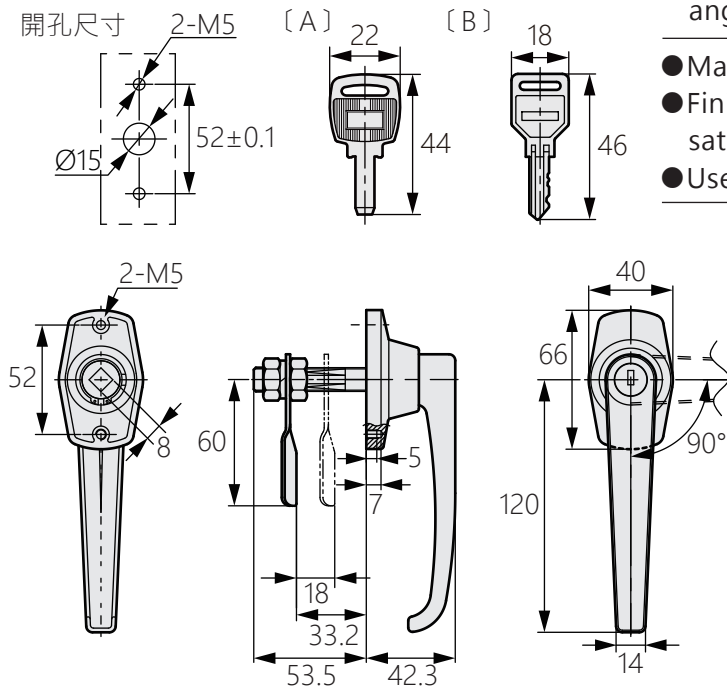

- Material: Zinc alloy(ZDC)
- Finish: Chrome plating(MZCr),black chrome plating satellite chrome plating,velour chrome plating
- Uses: Test instruments,control panels

*TM-517-1系列 沒有附鑰匙

*TM-517-2系列 有附鑰匙·A/B兩款可選款
例如：TM-517-2B-A

商品型號		表面處理
TM-517-1B	TM-517-2B	鍍黑鉻
TM-517-1C	TM-517-2C	鍍鉻
TM-517-1V	TM-517-2V	鍍絨鉻
TM-517-1KR	TM-517-2KR	衛星鍍鉻