



### 商品介紹 Product description

1. 一鍵式開合。
2. 左右兼用。
3. 指示燈功能可以快速知道鑰匙的鎖定狀態。
4. 側欄鍵適用。
5. 適用板厚：0.8-3mm。

- 材質：主框架-鋅合金 (ZDC) / 支架-冷軋鋼板 (SCP)
- 表面處理：主框架-鍍鉻 / 支架-鍍鋅 (MFZn)
- 用途：配電盤、機床等
- 備註：指示燈功能，如有需求型號請+"ID"

1. One-button opening and closing.
2. Use both left and right.
3. The indicator light function can quickly know the lock status of the key.
4. Side bar key applicable.
5. Applicable plate thickness: 0.8-3mm.

- Material: Main frame-Zinc alloy (ZDC) / Bracket-Cold rolling steel sheet(SCP)
- Finish: Main Frame-Satellite chrome plating/ Bracket-Zinc plating(MFZn)
- Uses: Switchboards, machine tools, etc.
- Notes: Indicator function, if you need a model, please add "ID".

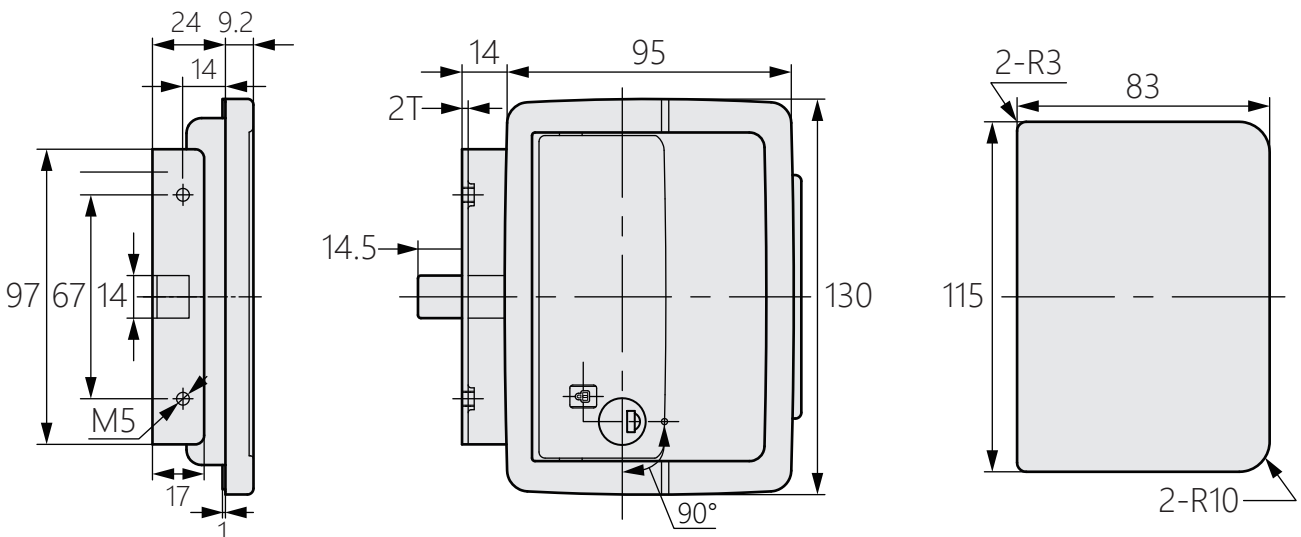

面板鑽孔尺寸

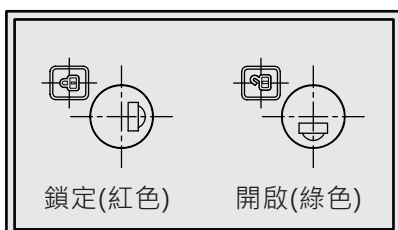
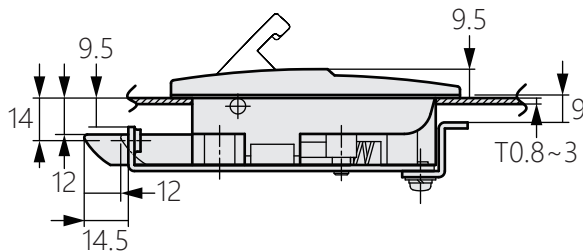

鑰匙狀態

\*如需指示燈功能可以型號+ID，例如：TM-531-1-1-ID

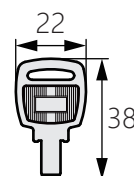

商品型號	固定配件
TM-531-1-1	鎖柄1個無門鎖
TM-531-1-2	鎖柄1個+門鎖1個
TM-531-1-3	鎖柄1個+門鎖2個